

Photographic Composition & Camera Techniques

Actively creating your photograph

Composition

Putting Together the Shot

Balance

- Achieving balance within your composition can be accomplished in several ways:
 - Symmetry
 - Using a visual counter-weight for a large mass
 - Color palette
 - Specific arrangement of large masses within the frame



Balance



Balance



Balance



Balance



Balance



Balance



Balance



Balance
Jerry Uelsmann



Balance
Russell Lee

Framing

- **Fill the frame**
 - Determine whether the subject's surroundings are important to the scene
 - If not, make the surroundings small in relation to the subject
- **Move in until all extraneous information is no longer in the scene**
 - Creates impact
 - Reveals more detail

Framing

- Don't treat your subject like a bullseye
- Do a "Walkaround"
 - Literally walk entirely around your subject, shooting from higher and lower heights and varying camera angles

Framing

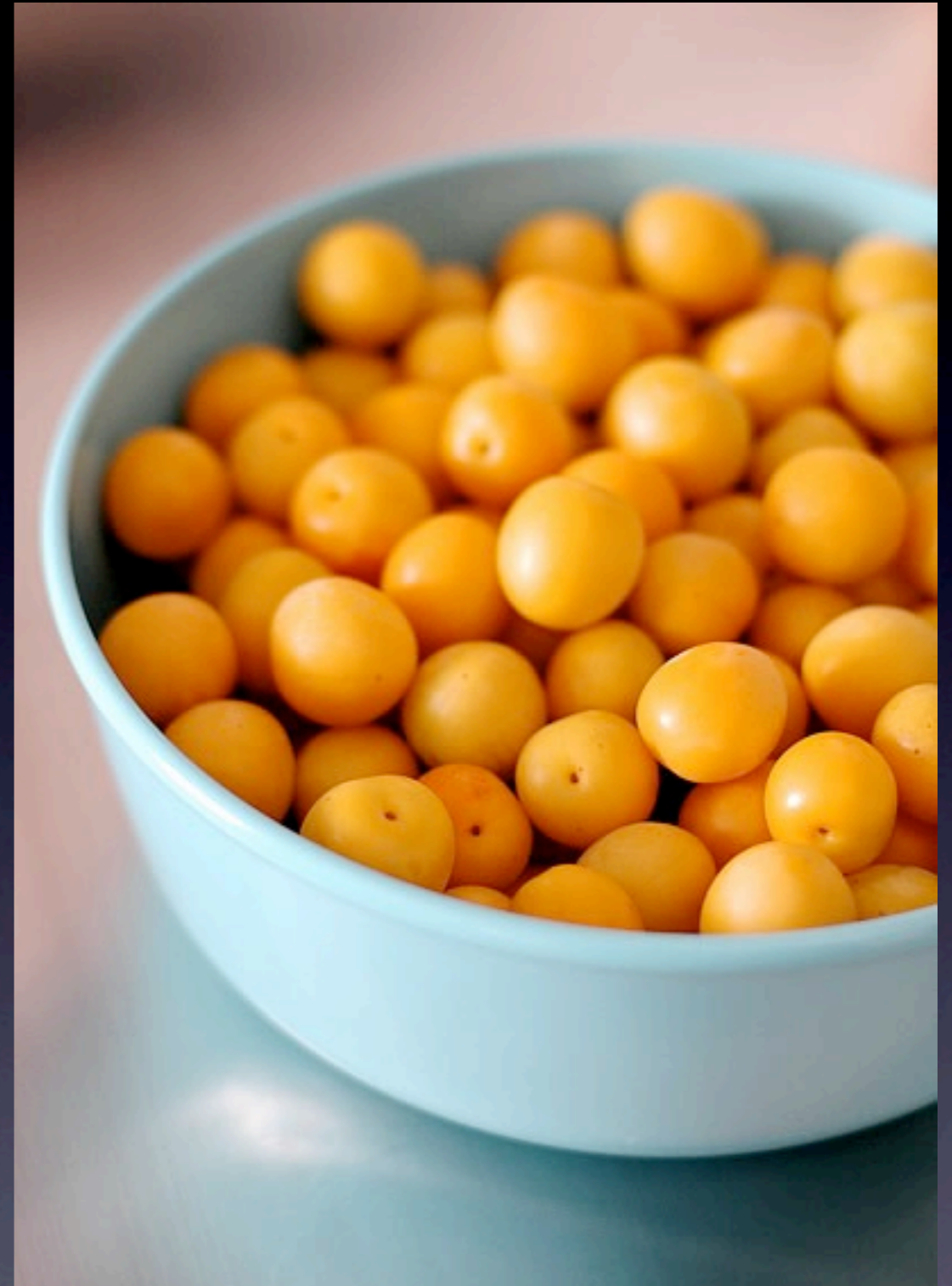



Framing



Framing

Framing

Edward Steichen





Framing

Framing



544 4028a-c

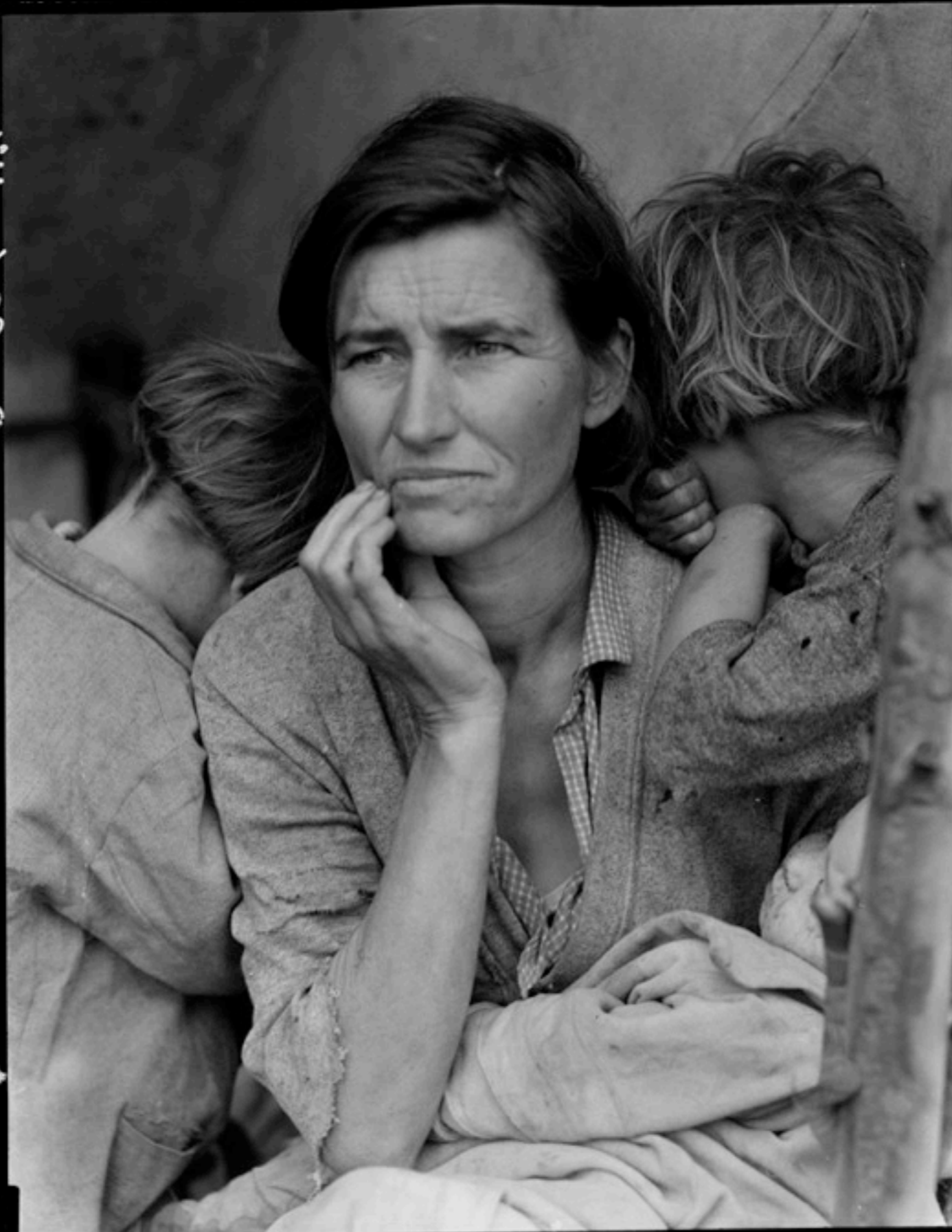

FASTMAN — NITRATE — KODAK
FASTMAN — NITRATE — KODAK

Balance
Dorthea Lange

Foreground / Background Relationship

- Include a foreground object to establish a sense of scale
- An overhanging branch or archway will provide depth, and guide the viewer's eye towards the subject
- Foreground details may contain information about the scene in the background



Foreground / Background



Foreground / Background

Foreground / Background





Foreground / Background



Foreground / Background



Foreground / Background



Foreground / Background

Leading Lines

- Lead the viewer's eye on a path through an image
- Direct the viewer's attention to a subject
- Can suggest a feeling or mood

Leading Lines

- Curved lines
 - A gently curved line suggests beauty and grace
 - A greatly bent line implies force
- Straight lines
 - Create a sense of rigidity and tension
 - Horizontal lines signify rest
 - Vertical lines signify balance
- Diagonal lines
 - Give a dynamic feeling of action or motion

Leading Lines





Leading Lines



Leading Lines

Jerry Uelsmann





Leading Lines



Triangle

Margaret Bourke-White

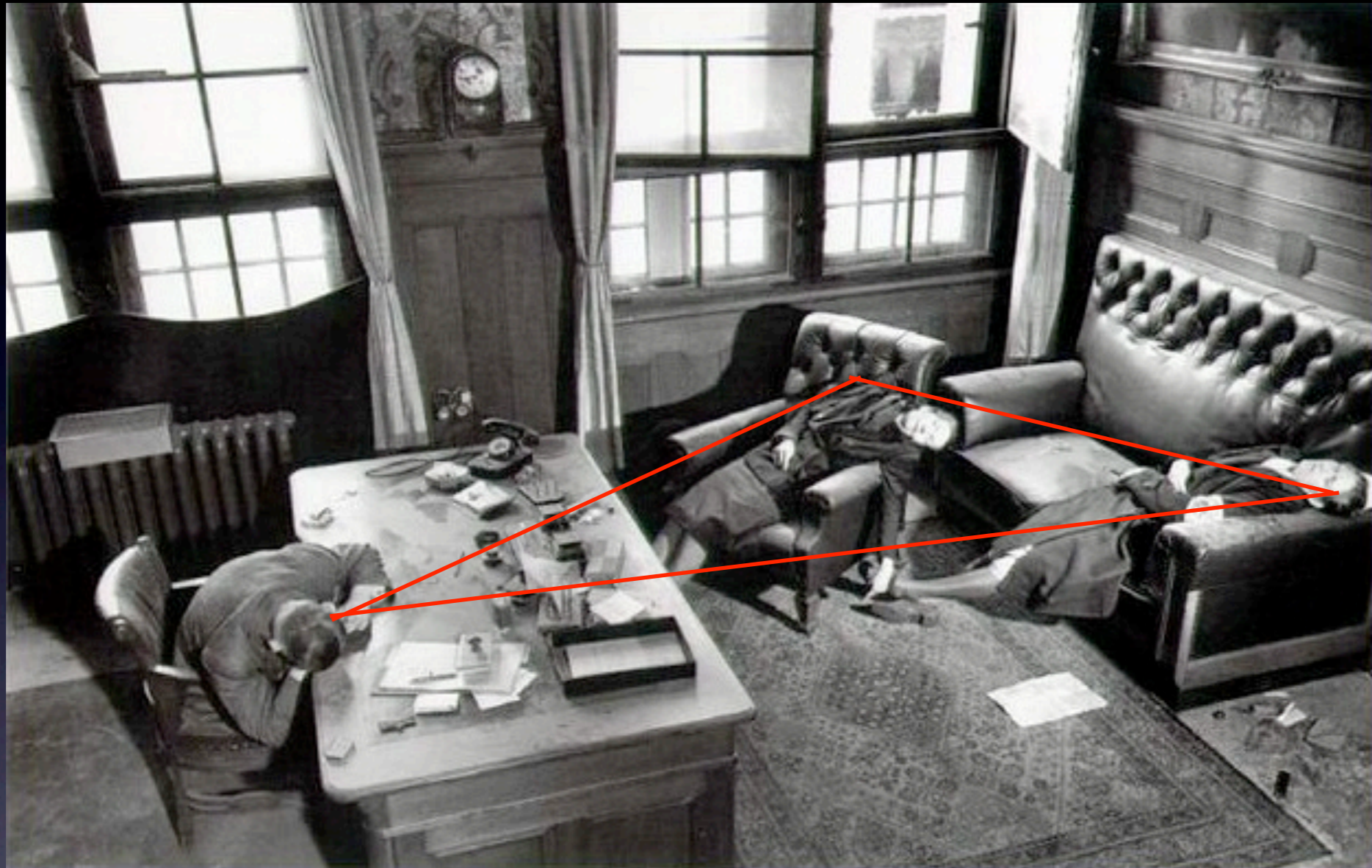

Triangle

Margaret Bourke-White

Triangle

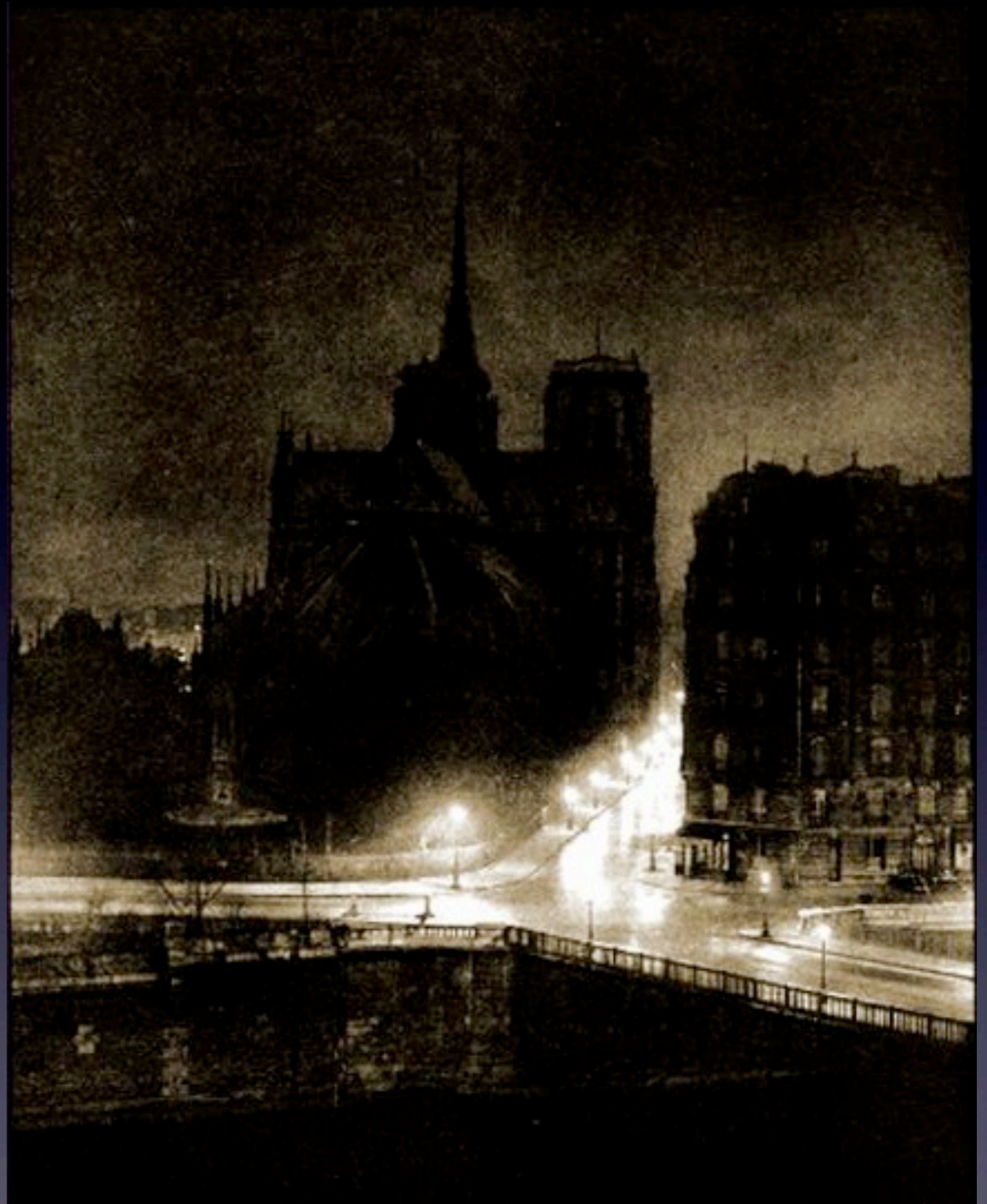

Triangle

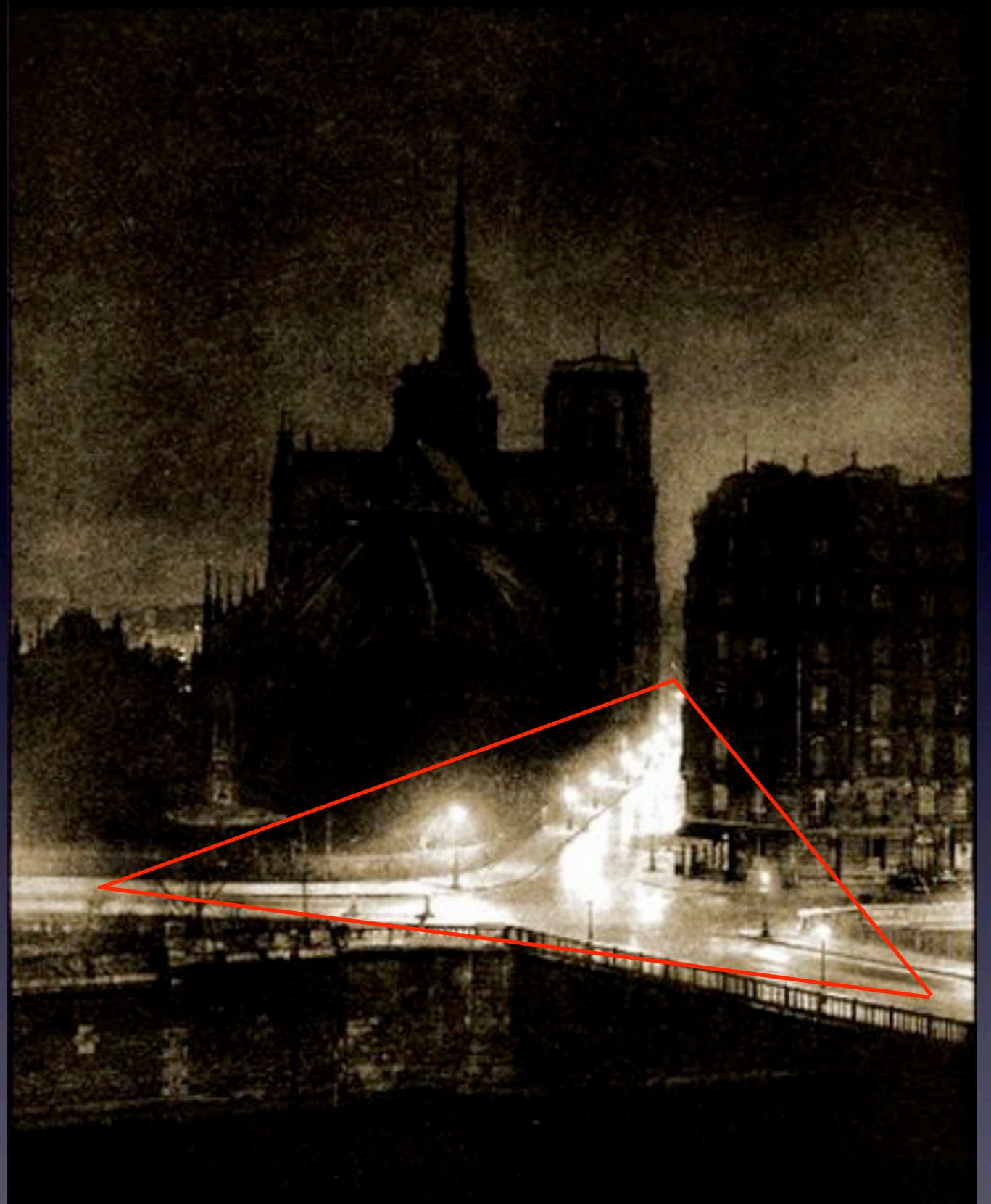

The Rule of Thirds

- A simple technique that will improve the way your photography looks, easily and immediately
- Origins trace back to the Golden Mean used by old masters to compose their paintings

The Rule of Thirds

- To use the Rule of Thirds, divide the frame into thirds both vertically and horizontally.
- Where the lines cross are 4 intersection points. These points are ideal locations to put your subject for a balanced composition.
- The horizon should be placed at either the upper third or lower third (horizontally).

The Rule of Thirds

The Rule of Thirds



The Rule of Thirds

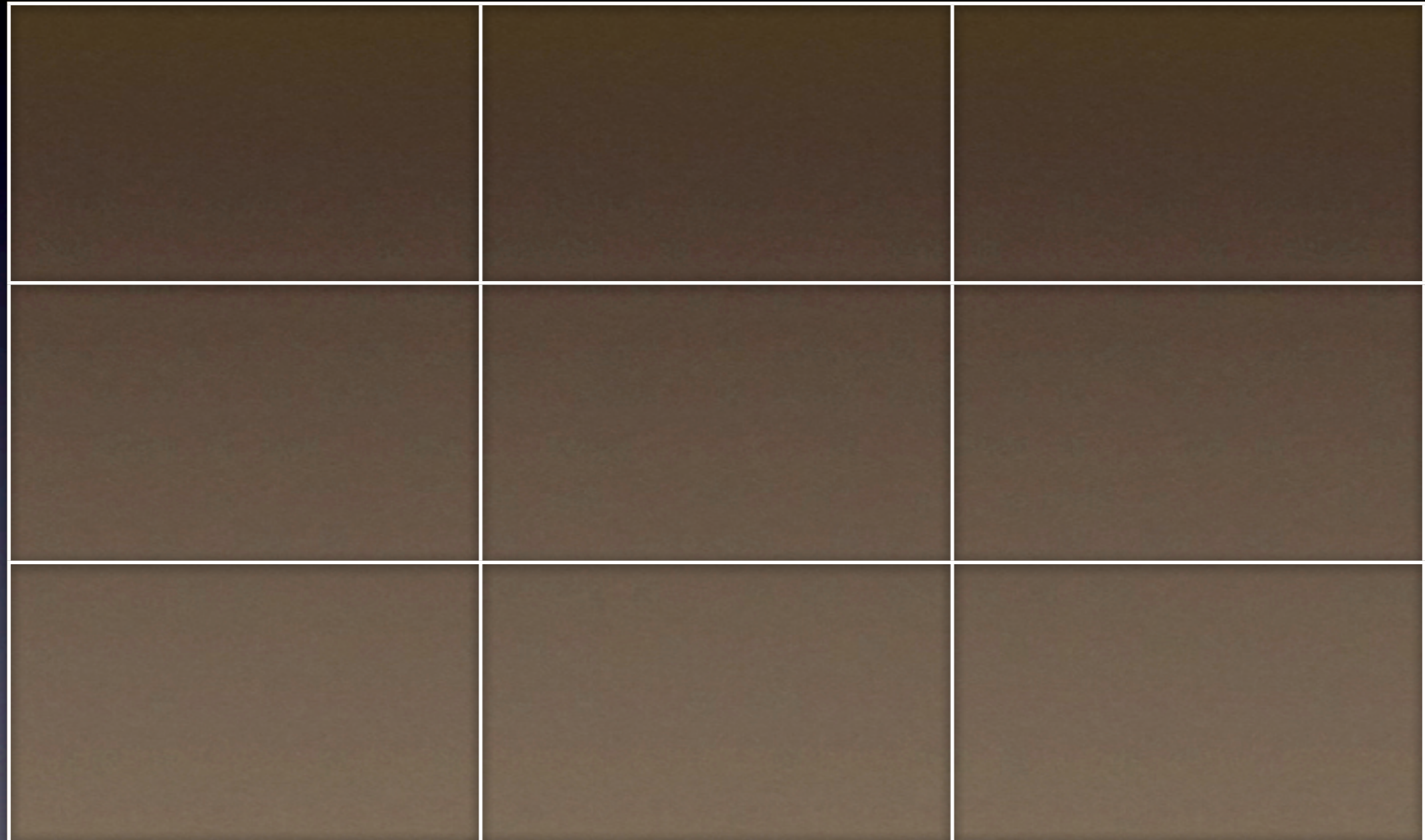

The Rule of Thirds

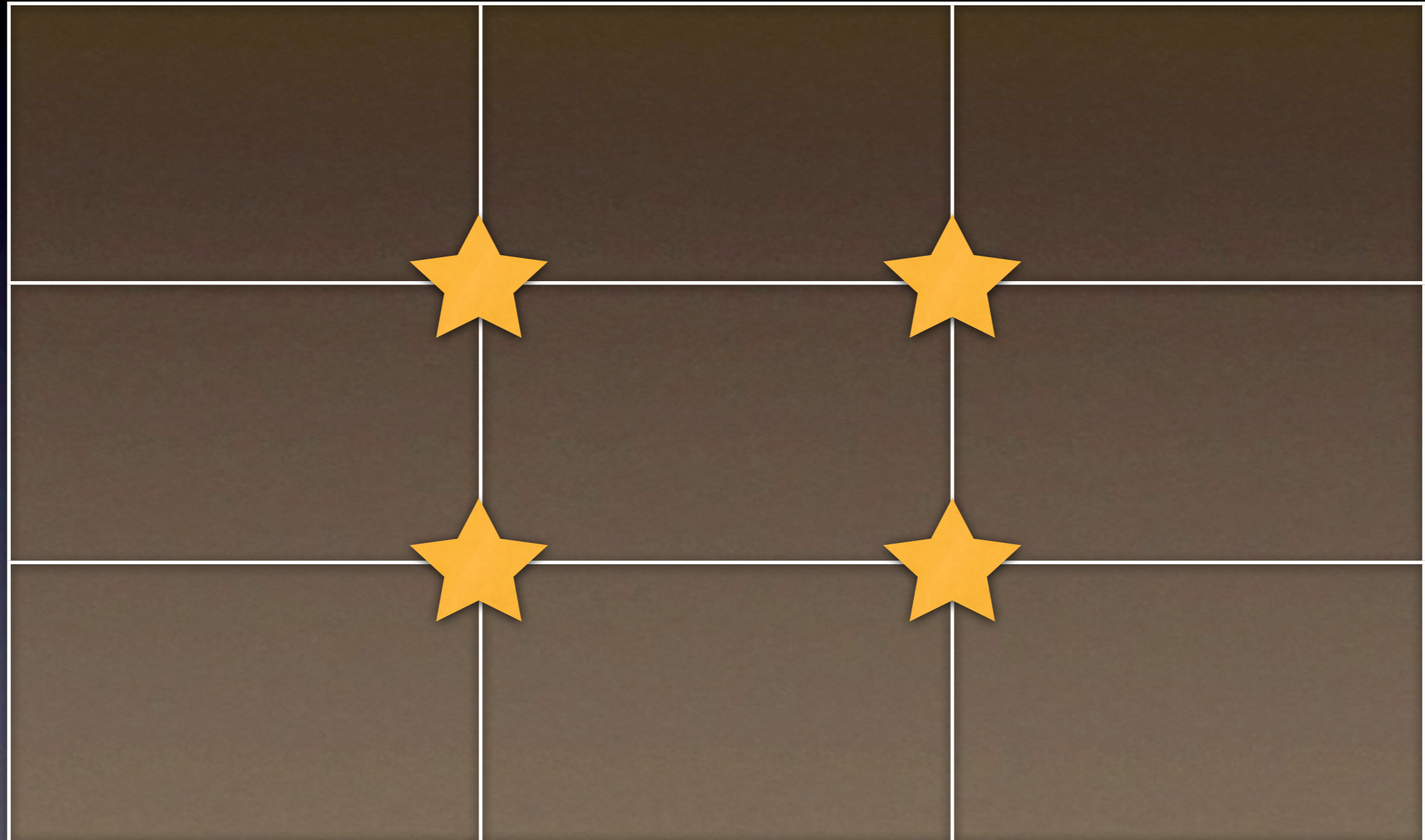



Rule of Thirds
Stephen Alvarez



Rule of Thirds
Stephen Alvarez



Rule of Thirds
Annie Griffiths Belt



Rule of Thirds
Annie Griffiths Belt

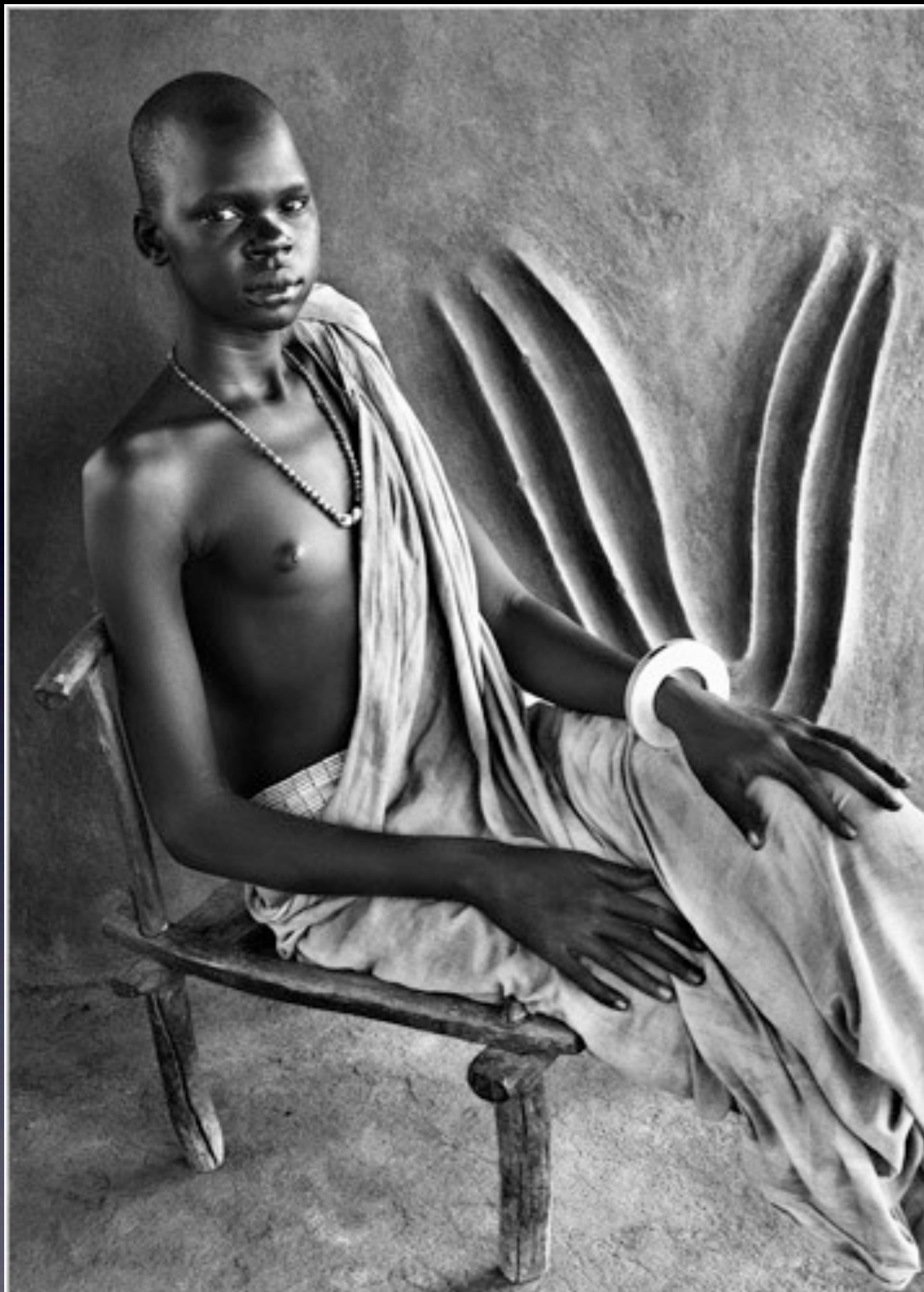

Rule of Thirds
Sebastiao Selgado

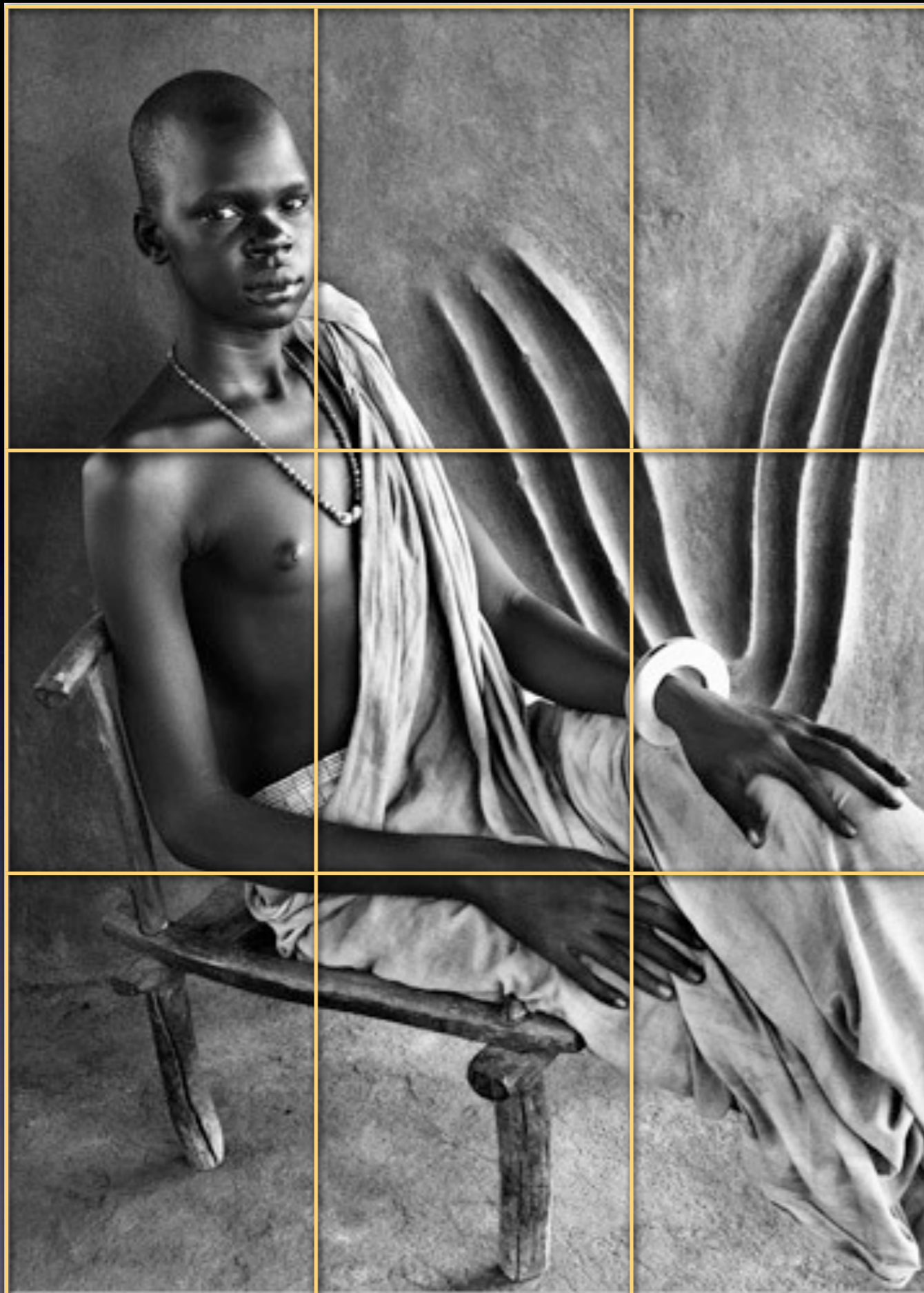

Rule of Thirds
Sebastiao Selgado



Rule of Thirds
Nick Cobbing



Rule of Thirds

Nick Cobbing

Rule of Thirds



Rule of Thirds





Rule of Thirds
Harry Callahan

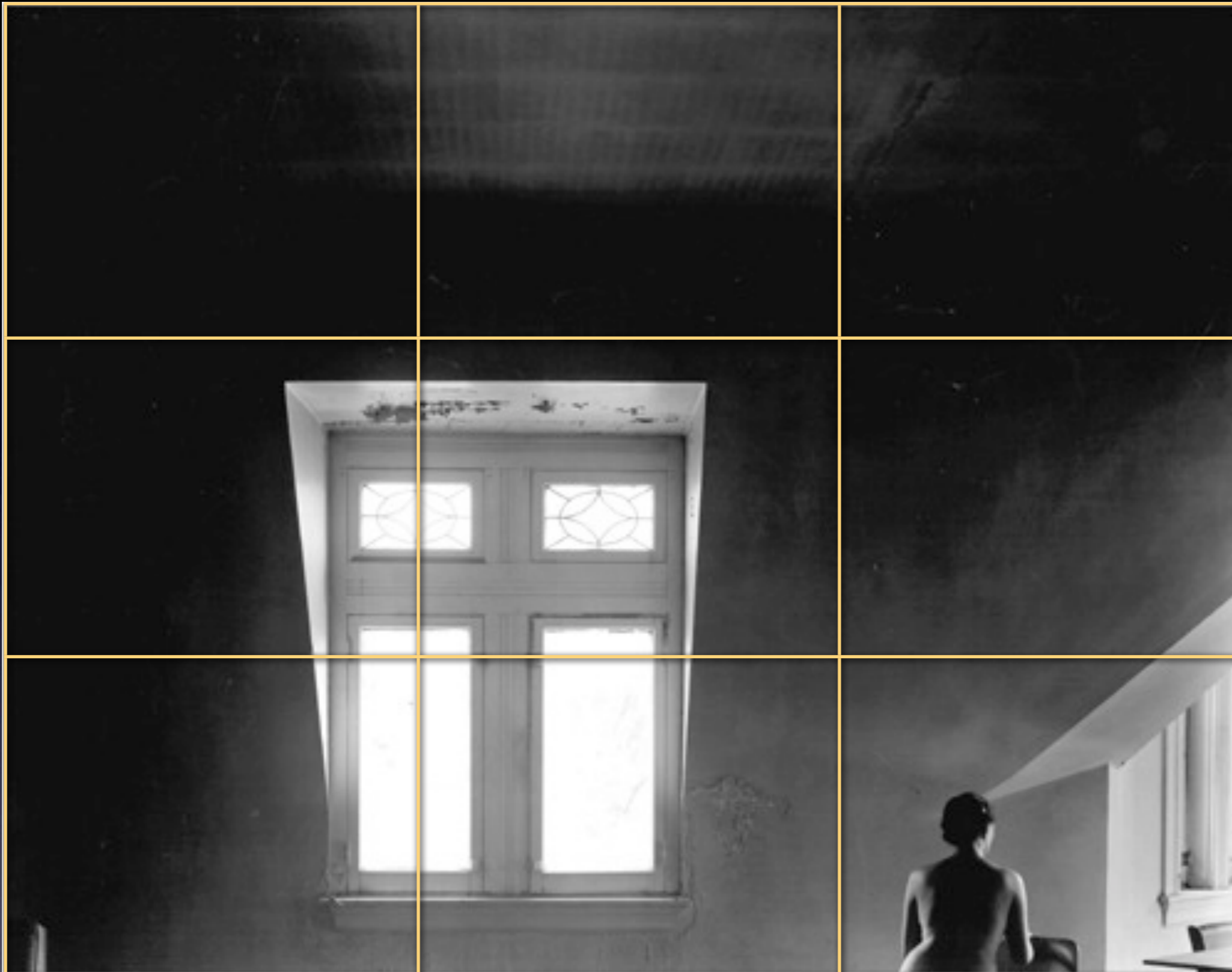

Rule of Thirds

Harry Callahan

Shape & Form

- **Shape** in photography refers to the 2-dimensional outline of an object
 - A silhouette is an example of shape in its purest form
- **Form** refers to the apparent 3-dimensionality of an object
 - A side-lit object reveals its true form with shadows and highlights

Emphasize Shape By:

- Contrasting it against a plain background
- Placing it against a background of opposing color
- Using backlighting
- Surrounding it with contrasting shapes
- Close cropping

Emphasize Form by:

- Using rim-lighting to reveal the edges
- Using side-lighting to reveal highlights and shadows around the shape and texture of the subject matter
- Avoid on-camera flash as it flattens out the subject

Form

Yousuf Karsh

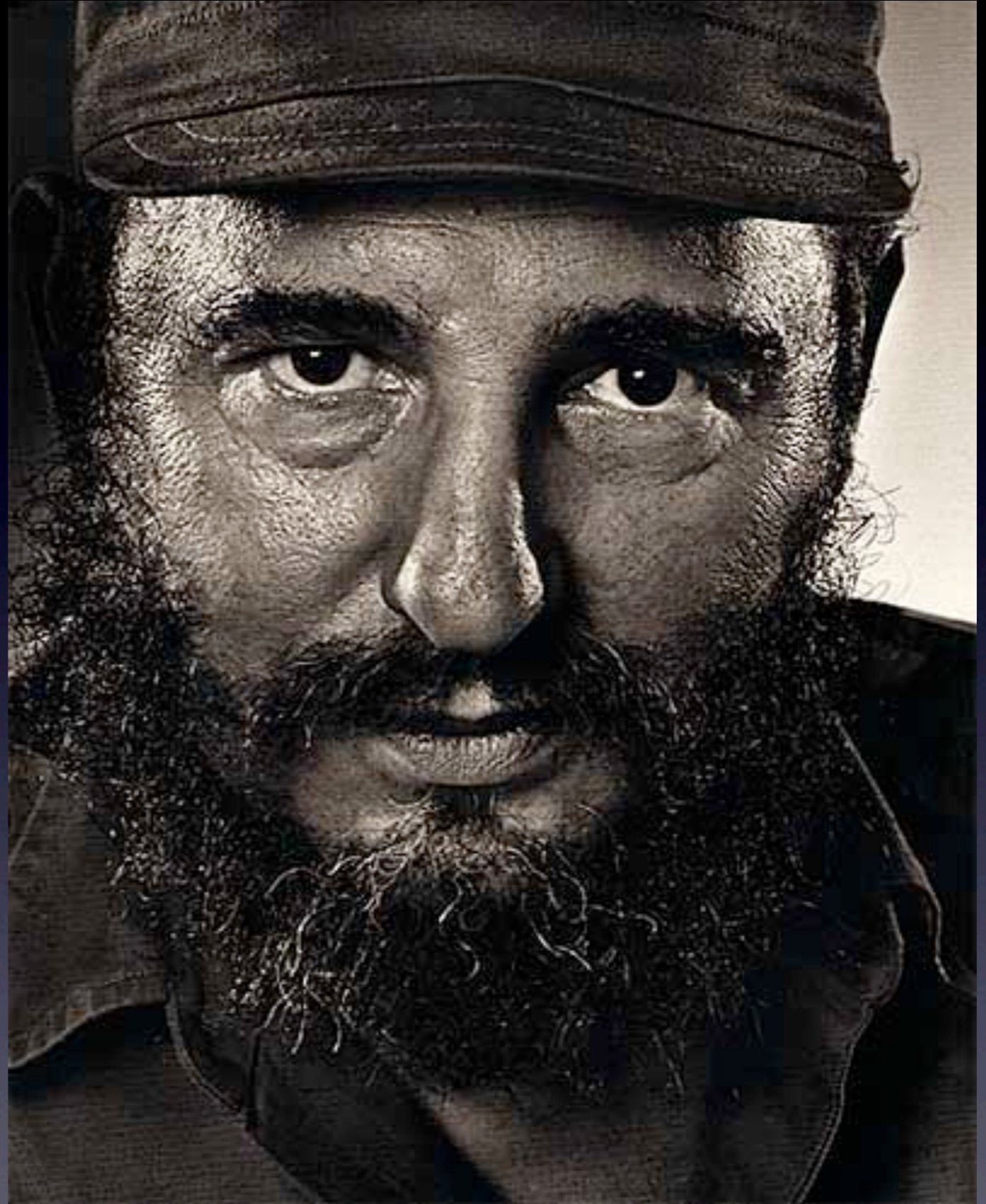

Form

Yousuf Karsh

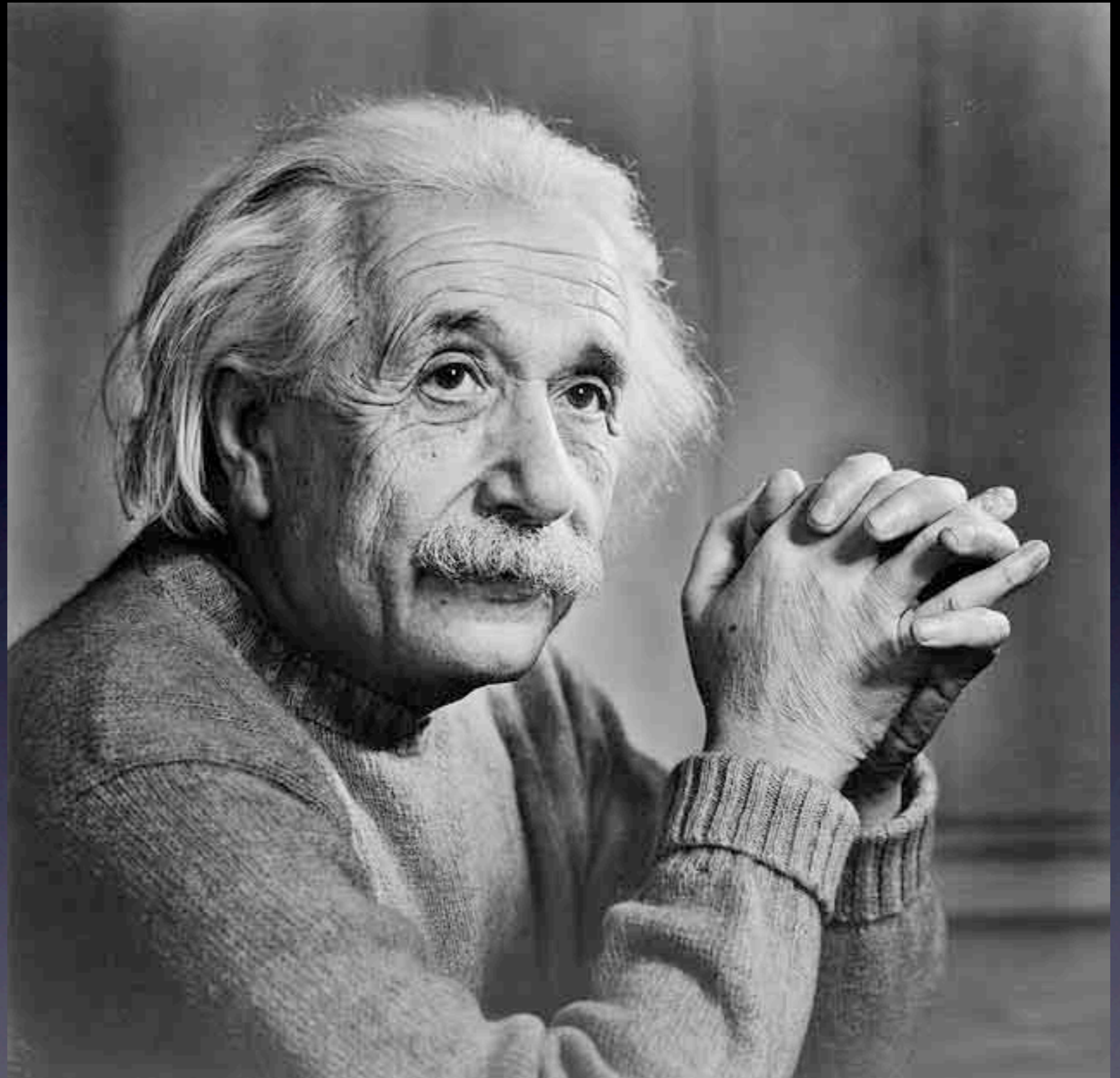

Form

Loretta Lux





Form

Form

Loretta Lux





Shape

Shape

Dorthea Lange





Shape



Shape & Form
James P. Morse

Shape

Dorothea Lange





Shape

The Decisive Moment

- Made famous by photographer Henri Cartier-Bresson after he published a book of the same name
- Cartier-Bresson is widely considered to be the father of modern photojournalism, being an early adopter of the 35mm format and developer of “street photography”

The Decisive Moment

“There is a creative fraction of a second when you are taking a picture. Your eye must see a composition or an expression that life itself offers you, and you must know with intuition when to click the camera. That is the moment the photographer is creative.”

- Henri Cartier Bresson



The Decisive Moment

Henri Cartier-Bresson

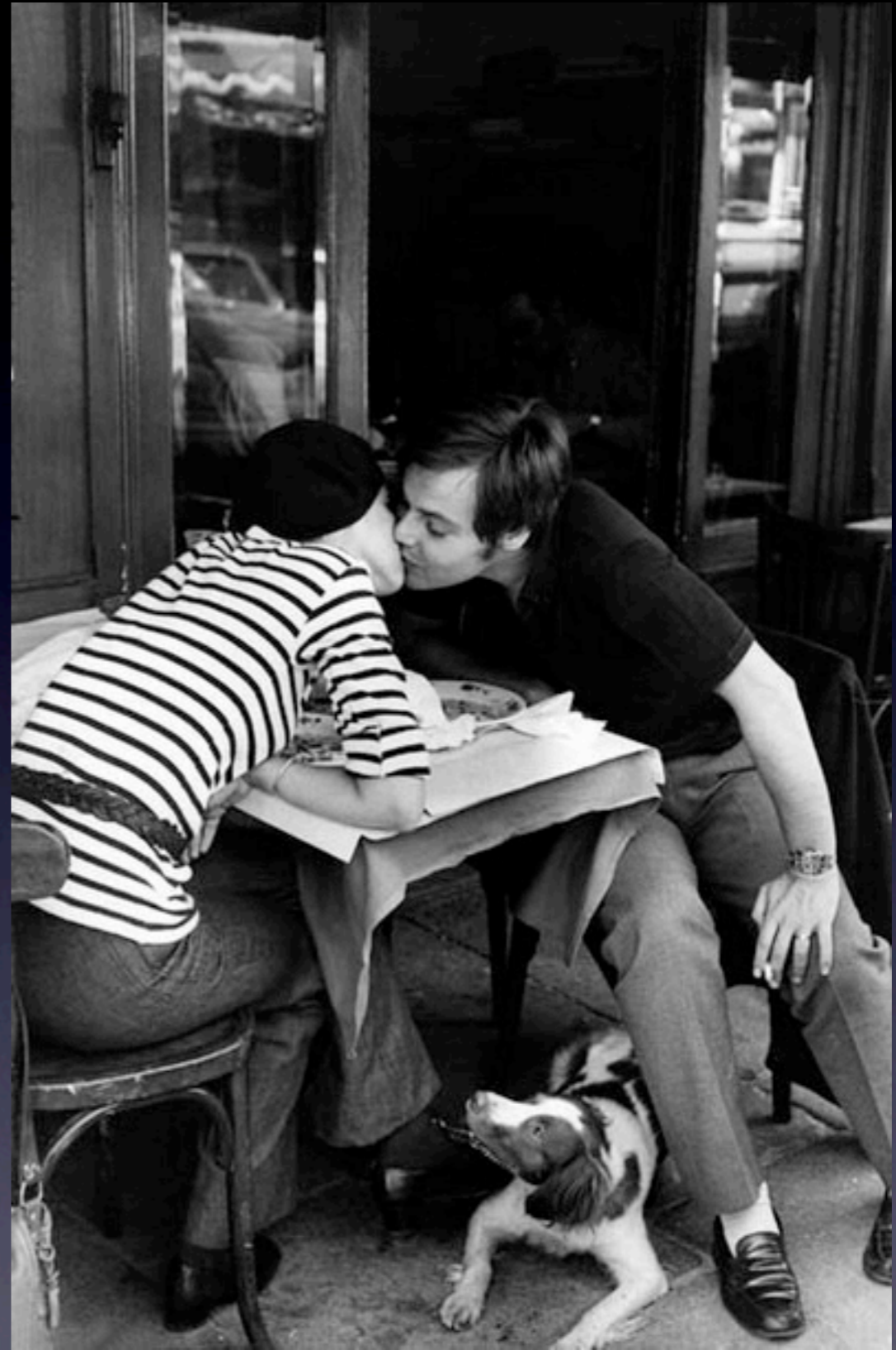

The Decisive Moment

Henri Cartier-Bresson



The Decisive Moment

merelyok



KODAK 100TMAX

44

KODAK



The Decisive Moment
Roberto Delduque



The Decisive Moment

sans.otto

All About the Camera

Plus Creative Controls to Make Exposures

Megapixels

- Megapixels - millions of pixels
 - A 10 megapixel sensor will cover most uses
 - 12 to 14 megapixels allows more room for cropping, and larger printing uses
 - 21 megapixels and up create an increased burden on hardware and software with the increased file size, but allow for extreme cropping and large format print sizes

Megapixel Print Chart

Inches @ 300 ppi

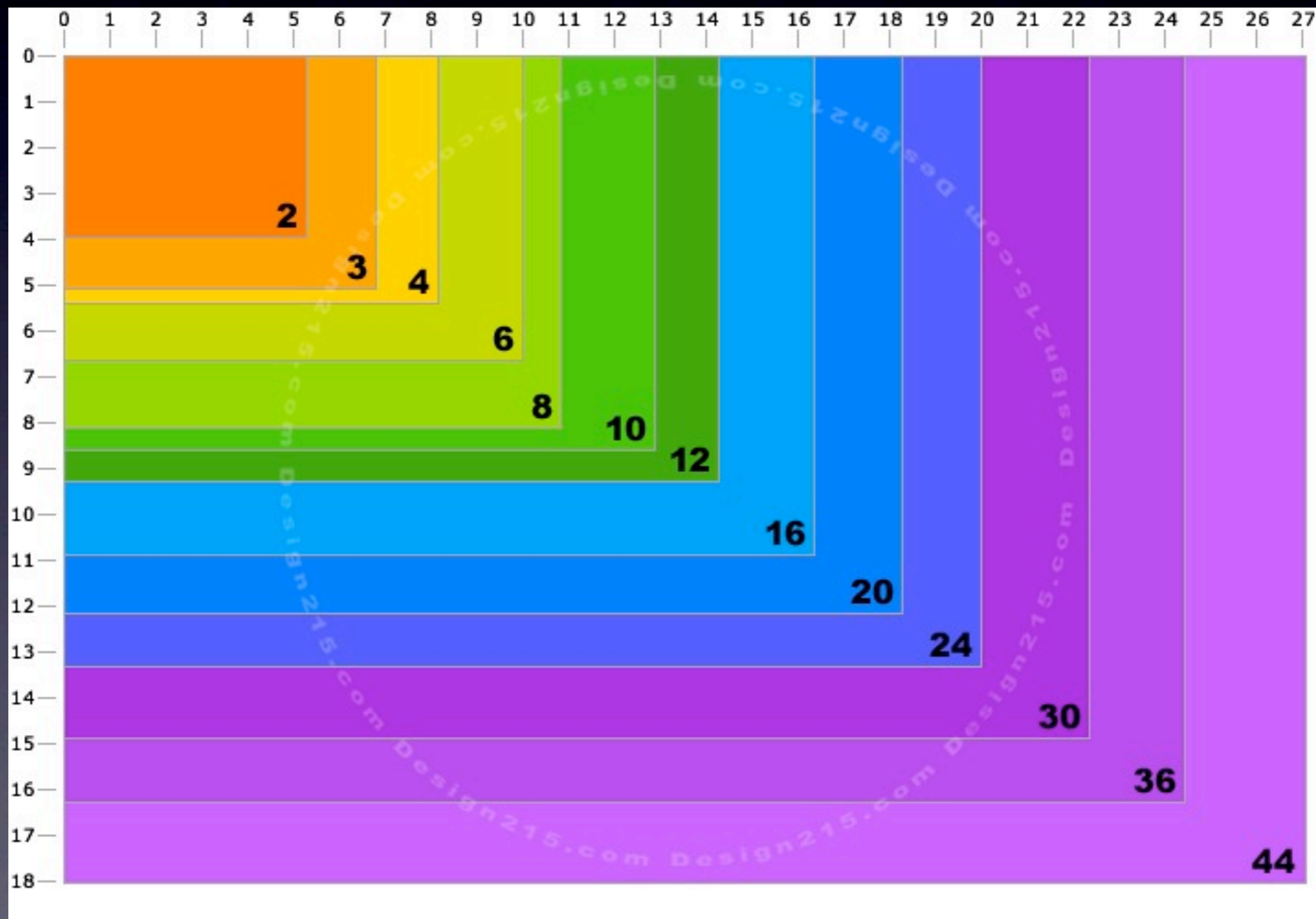

Imaging Sensors

- Many prosumer digicams come in the 4:3 aspect ratio, while most DSLRs are 3:2, matching 35mm film
- “Full Frame” sensors are the same size as 35mm film at 36mm x 24mm
- Reduced Frame sensors (APS-C) are comparative to the Advanced Photo System size at 22mm x 15mm
- Using a full frame lens on a APS-C sensor magnifies the focal length of approximately 1.5
 - A 35mm lens on a APS-C sensor would be about 52mm
- Larger sensors afford greater dynamic range and lower noise

The ISO

- The term “ISO” stands for the International Standardization Organization, which set standards to indicate how sensitive different films were to light
 - The lower the number, the less sensitive it is to light and the finer the film grain
 - Film ISOs ranged from 100, 200, 400, 800, etc.
- The same principles apply to digital photography, except the ISO measures the imaging sensor’s sensitivity to light

The ISO Setting

- Higher ISOs (400, 800, 1600, 3200) are best used for darker environments when you need more light to make an exposure
 - An example is shooting a band playing in a music venue
 - The cost is more digital noise/grain in the shots
- Lower ISOs (70, 100, 200) are best suited for bright light situations
 - An example is shooting in direct sunlight
 - There is less digital noise/grain at lower sensitivity, plus it allows for use of a greater range of aperture settings

5000 ISO



Low Light Scenario

100 ISO



Bright Light Scenario

A close-up photograph of a pink chrysanthemum flower. The petals are densely packed and show a soft, natural texture. A yellow rectangular box is overlaid in the upper right corner of the image.

3200 ISO

A close-up photograph of a pink chrysanthemum flower, identical to the one on the left but captured at a lower ISO setting. The petals appear smoother and less detailed. A yellow rectangular box is overlaid in the upper right corner of the image.

100 ISO

Different ISO Settings & Noise

The Shutter

- The shutter is the mechanism that exposes light to film or an imaging sensor, and there are two types:
 - A **leaf shutter** is in the lens assembly of most medium format and large format lenses, and consist of a series of blades that snap open
 - A **focal plane shutter** is located directly in front of the image plane, and is best described as two curtains, one opening and the other closing
- The shutter speed selection determines the length of time the imaging sensor is exposed, for example, 1/8000 of a second or 1 full second.

Focal Plane Shutter

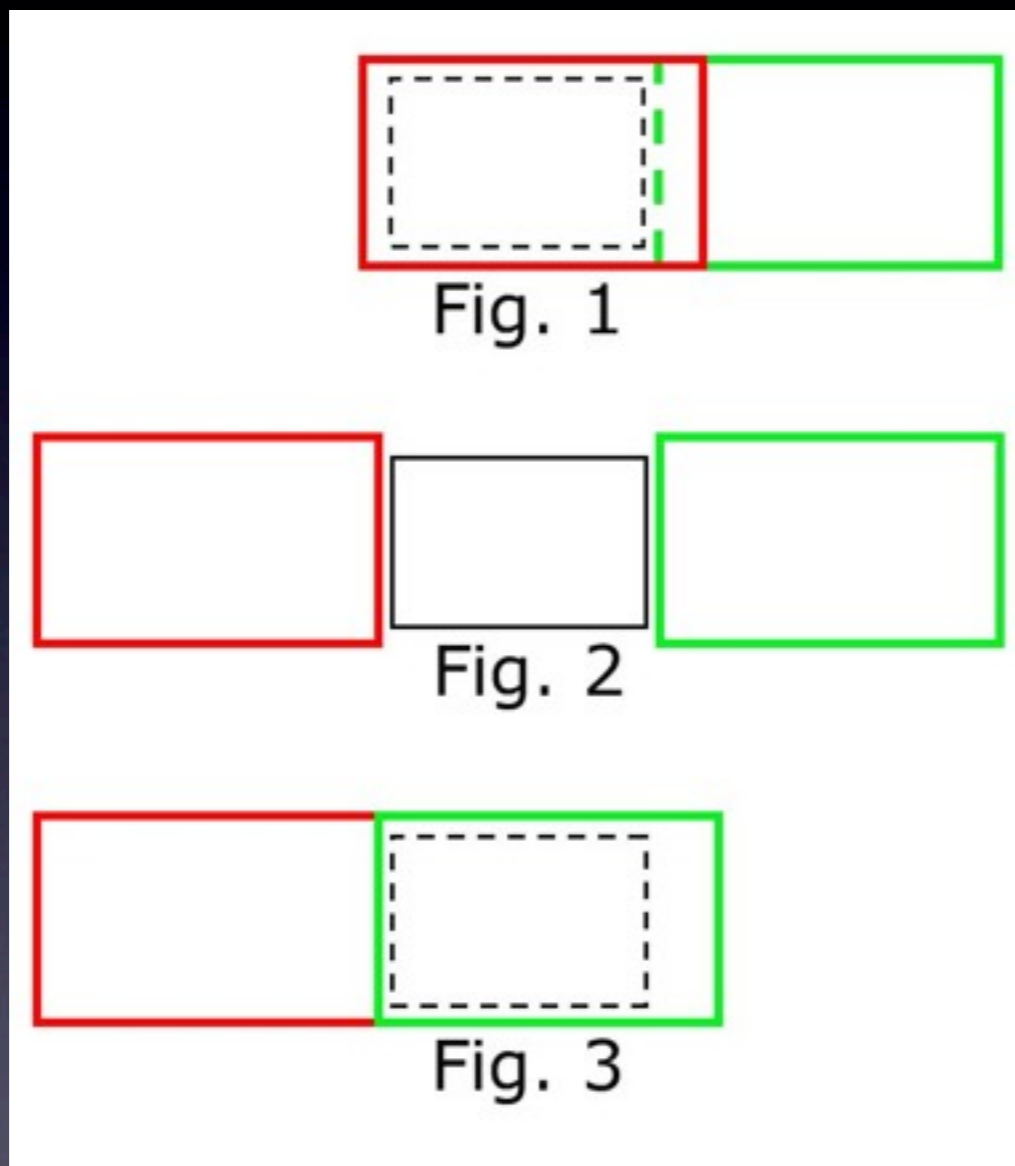

Low Speed

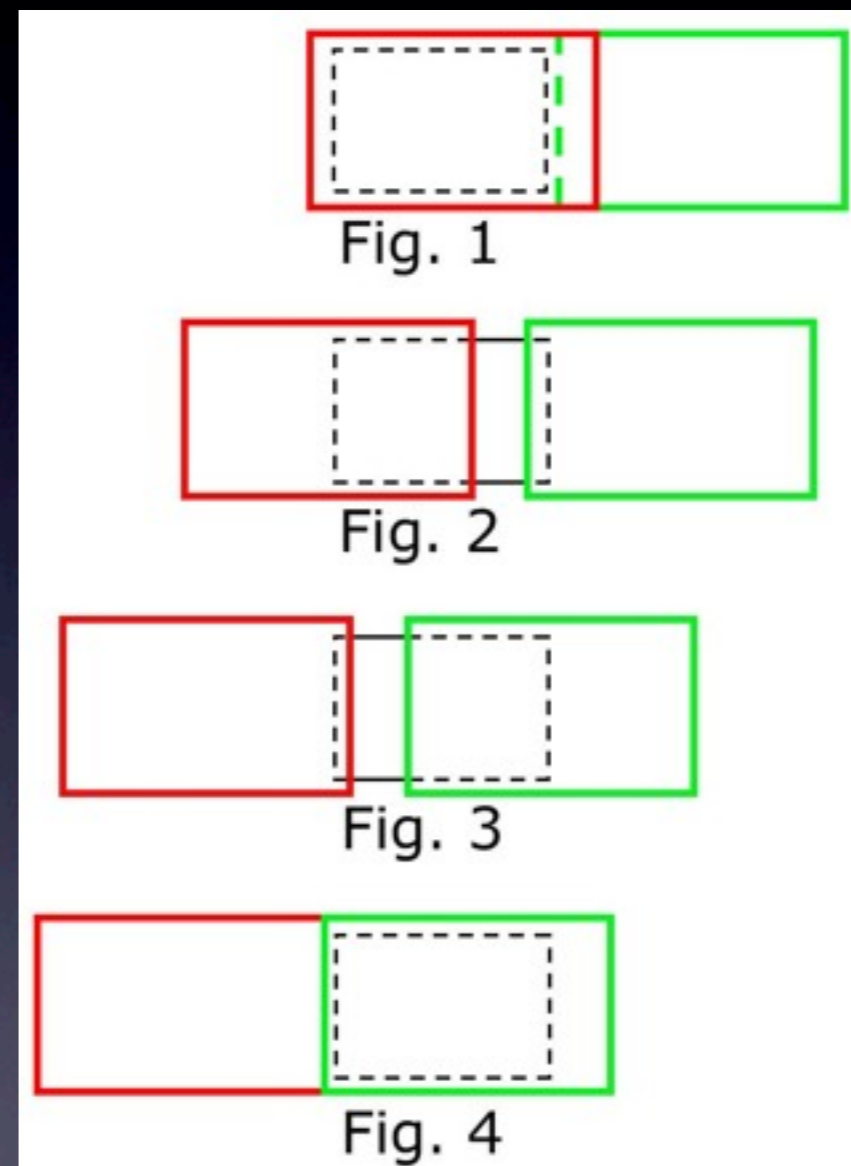

High Speed

Using the Shutter

- Creative use of the shutter speed setting allows the photographer to freeze or blur a subject's motion in the frame
- Leaf shutters can sync with flash at any available camera speed
- Focal plane shutters can only sync up to 1/1000 sec.



Shutter Priority (Tv)

- Shutter Priority is generally a mode on DSLR's labeled Tv, which stands for Time Variable.
- In this mode, you select the shutter speed you want to shoot with, and the camera will select the proper aperture setting (to get enough light) to result in a good exposure.
- If you select too fast of a shutter speed for the lighting conditions and your ISO setting, the camera will flash the aperture setting to indicate that you will not make a proper exposure



Friday, February 12, 2010



1/250 sec.



Friday, February 12, 2010



Friday, February 12, 2010



1/8 sec.



Shutter Priority



1 sec.

Shutter Priority



Shutter Priority



7 sec.

Shutter Priority



Shutter Priority



1/1000 sec.

Shutter Priority



Shutter Priority



1/8000 sec.

Shutter Priority

The Aperture

- The aperture is the opening on the lens through which light passes when the shutter is open
- The aperture is measured in f-stops such as $f/2.8$ or $f/16$
- The smaller the f-stop number, the larger the opening, and visa versa



The Relationship Between the Aperture & F-stop Number

- Say the diameter of a selected aperture on a standard 50mm lens measures 12.5mm
- This measurement divides into the focal length of the lens (50mm) exactly 4 times
- Therefore, the f-stop is labeled f/4
- The measurement of a larger numbered f-stop divides into the focal length more times, thus the larger number such as f/22

The Aperture & F-stops

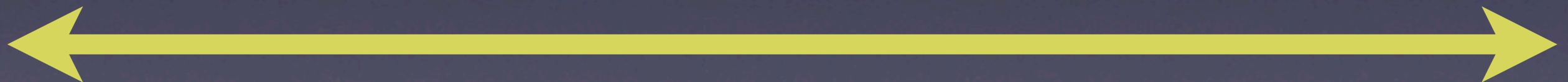
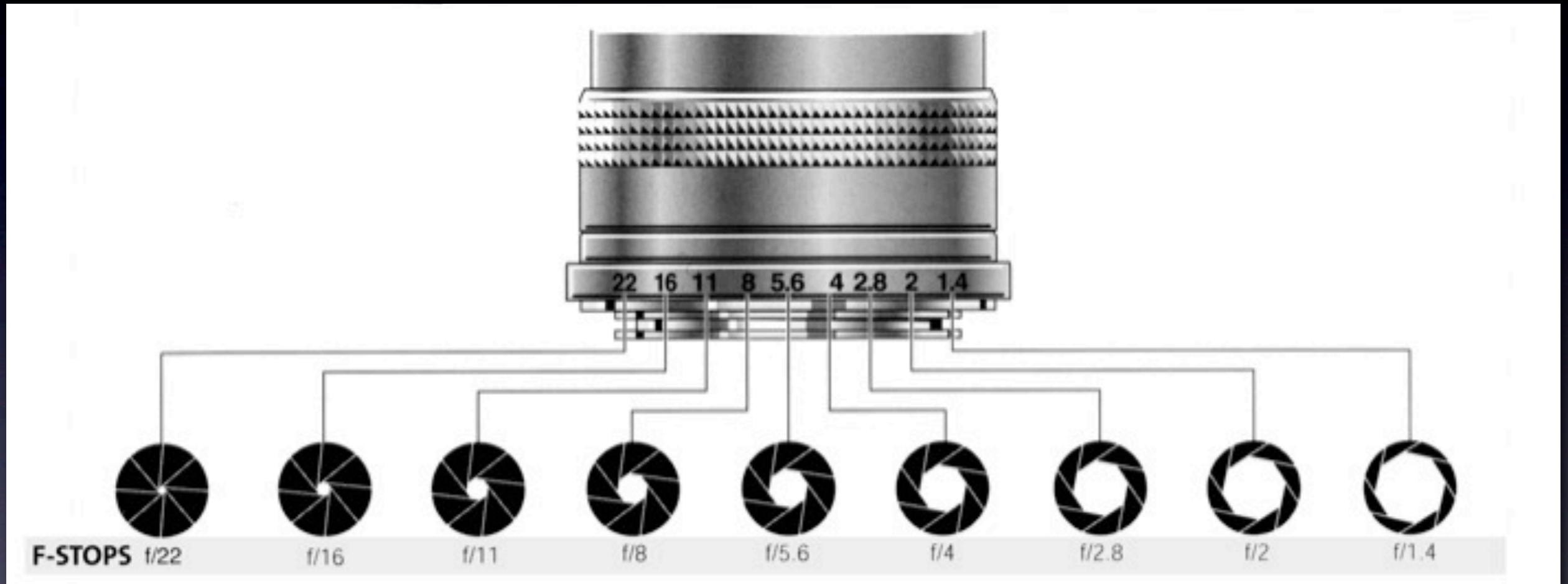

Larger F-stop Numbers
Smaller Openings
Lets Less Light In

Smaller F-stop Numbers
Larger Openings
Lets More Light In

The Relationship Between the Aperture & Depth of Field

- Depth of field is defined as the range of acceptable sharp focus within an image.
- Shallow or small depth of field is achieved by using apertures with the widest openings, which are the smallest f-stop numbers
 - Examples: $f/1.4$, $f/2.8$, $f/4$
- Maximum depth of field is achieved by using apertures with the smallest openings, which have the largest f-stop numbers
 - Examples: $f/11$, $f/16$, $f/22$

The Aperture & F-stops

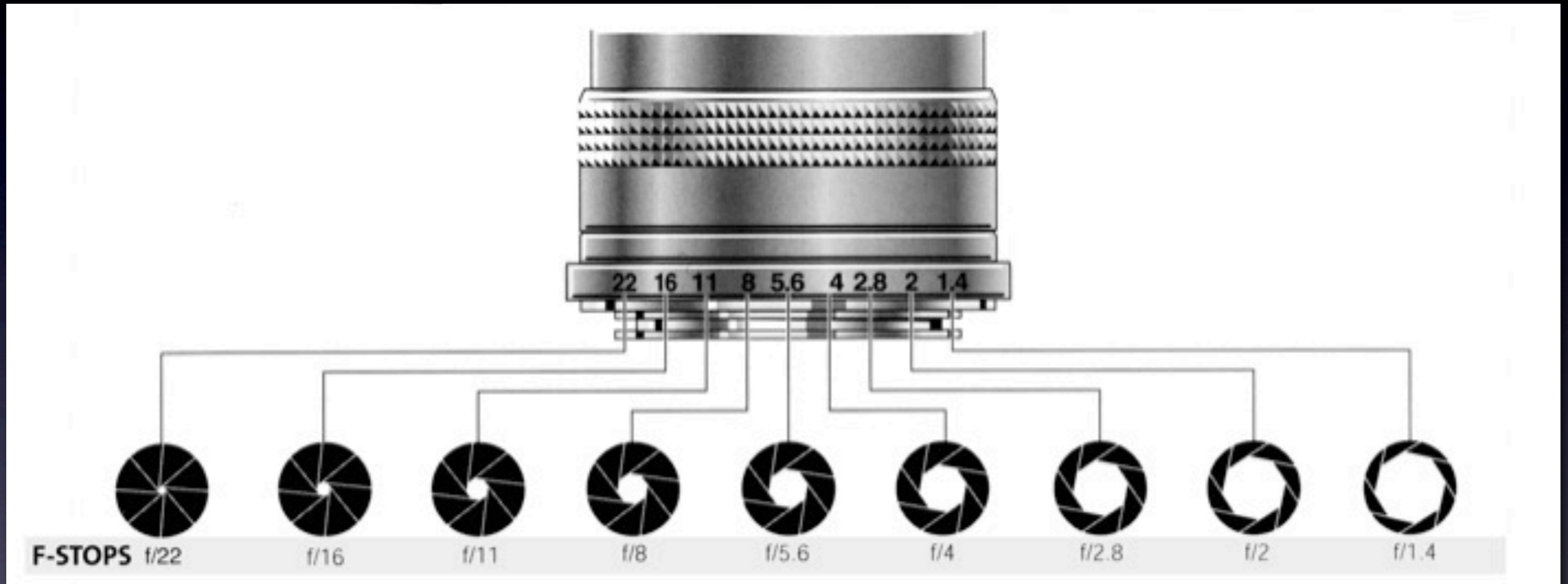

Larger F-stop Numbers
Smaller Openings
Deep Depth of Field

Smaller F-stop Numbers
Larger Openings
Shallow Depth of Field

Aperture Priority (Av)

- Aperture Priority is generally a mode on DSLR's labeled Av, which stands for Aperture Variable.
- In this mode, you select the f-stop you want to shoot with, and the camera will select the proper shutter speed to result in a good exposure.
- This is one of the most popular settings for a photographer because it allows one to control the depth of field in an image.

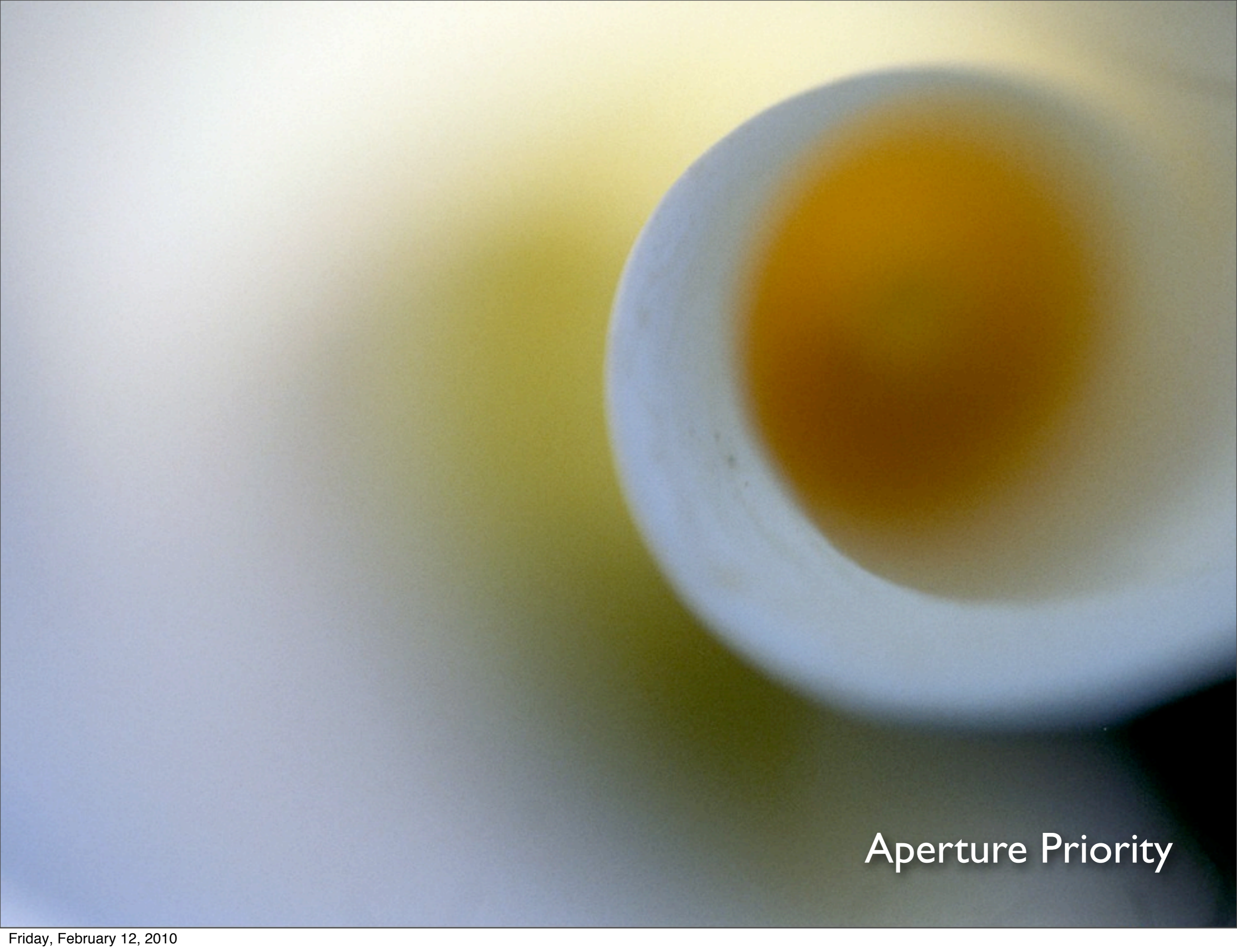

Aperture Priority

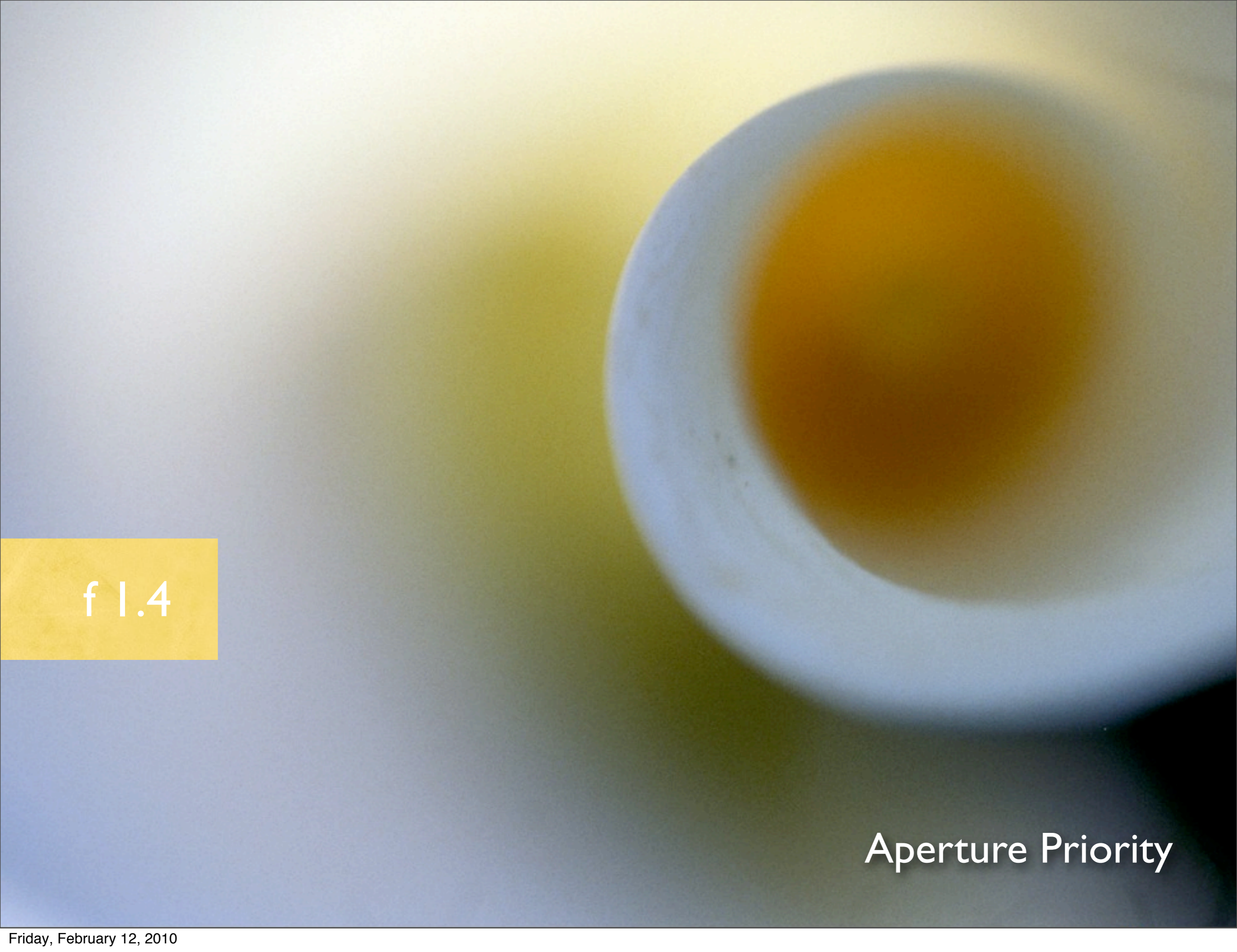

f 1.4

Aperture Priority



Aperture Priority



f 4

Aperture Priority



Friday, February 12, 2010



奔向 2008

通州大运河
冬泳队

f 8 to f 11



Aperture Priority

f 22 or more



Aperture Priority

Factors Affecting Depth of Field

- **Distance** - the closer you are to your subject, the narrower the depth of field. Move further away and the depth of field becomes greater.
- **Focal length** - telephoto lenses flatten perspective, thus appearing to make images appear to have shallower depth of field.

Other Camera Modes

(For when you don't have Manual or Av/Tv options)

Portrait Mode

Generally selects a wide aperture (ex. f/4), for a shallower depth of field

Landscape Mode

Generally selects a small aperture (ex. f/16), for a deeper depth of field

Night Mode

Selects a wide aperture and long shutter speed to shoot in low light

Action Mode

Selects a fast shutter speed to stop motion



Quality of Light

- The quality of light can completely alter the perception of an environment or person
- Take lighting into consideration every time you shoot
 - Avoid shooting during the middle of the day outdoors in direct light (the same hours you might get sun-burned)
 - Dusk and dawn shooting offers warm or cool lighting from lower angles



Back-light



Available / Indirect Light



Window Light



Dusk / Dawn Photography



Overcast Light

Composition Review

- Actively decide what to include in the frame, and how to arrange it visually
- Balance
- Framing
- Foreground / Background
- Leading Lines
- The Rule of Thirds
- Shape
- Form
- The Decisive Moment

Camera Techniques Review

- ISO Setting

Camera Techniques Review

- ISO Setting
 - Controlling the sensitivity to light

Camera Techniques Review

- ISO Setting
 - Controlling the sensitivity to light
- Shutter Speed Settings

Camera Techniques Review

- ISO Setting
 - Controlling the sensitivity to light
- Shutter Speed Settings
 - Shutter Priority (Tv)

Camera Techniques Review

- ISO Setting
 - Controlling the sensitivity to light
- Shutter Speed Settings
 - Shutter Priority (Tv)
 - Use to freeze or reveal motion

Camera Techniques Review

- ISO Setting
 - Controlling the sensitivity to light
- Shutter Speed Settings
 - Shutter Priority (Tv)
 - Use to freeze or reveal motion
- The Aperture & F-Stops

Camera Techniques Review

- ISO Setting
 - Controlling the sensitivity to light
- Shutter Speed Settings
 - Shutter Priority (Tv)
 - Use to freeze or reveal motion
- The Aperture & F-Stops
 - Aperture Priority (Av)

Camera Techniques Review

- ISO Setting
 - Controlling the sensitivity to light
- Shutter Speed Settings
 - Shutter Priority (Tv)
 - Use to freeze or reveal motion
- The Aperture & F-Stops
 - Aperture Priority (Av)
 - Use to control the range of your depth of field

Camera Techniques Review

- ISO Setting
 - Controlling the sensitivity to light
- Shutter Speed Settings
 - Shutter Priority (Tv)
 - Use to freeze or reveal motion
- The Aperture & F-Stops
 - Aperture Priority (Av)
 - Use to control the range of your depth of field
- Camera Modes on Automatic Cameras